

Benjamin Franklin House Education Pack

"The doors of wisdom are never shut"
- Benjamin Franklin



Contents

Our Mission.....	Pg 3
Why Visit Benjamin Franklin House.....	Pg 4
Benjamin Franklin House and the National Curriculum.....	Pg 5

Pre-Visit

Planning your visit.....	Pg 7
How to book.....	Pg 8
Setting Objectives.....	Pg 9
Preparing your Pupils.....	Pg 10

An Enlightening Day

The Historical Experience.....	Pg 12
Student Science Centre.....	Pg 12-20

Back at School.....	Pg 21
---------------------	-------

Other Curricular Enrichment opportunities with Benjamin Franklin House.....	Pg 23
---	-------

Appendices:

I. What is special about Benjamin Franklin and his London House.....	Pg 24
II. Franklin the Scientist – A Timeline.....	Pg 28
III. Further reading.....	Pg 29
IV. Pre-visit checklist.....	Pg 31
V. How to get to Benjamin Franklin House.....	Pg 32
VI. Other relevant attractions to visit.....	Pg 33

Contact details:

Gemma Smith

Education Manager

Benjamin Franklin House

36 Craven Street

London WC2N 5NF

Telephone: +44 (0)207 839 2013

Email: education@benjaminfranklinhouse.org

1. Our Mission

At Benjamin Franklin House, the mission of our Education Programme is to:

- Raise awareness of and appreciation for the contributions Benjamin Franklin made in the fields of science, innovation, civic engagement and politics, while highlighting how we continue to benefit from many of Franklin's contributions today; and
- Foster a positive attitude to history and museums by providing pupils with the opportunity to take part in enjoyable, active, curricular learning experiences in our historic house setting.

This Pack has been developed to support teachers in planning a meaningful visit to Benjamin Franklin House, and has been created with four key objectives in mind:

- 1) To promote learning about Benjamin Franklin – a unique figure in history who prioritised learning; and to offer new perspectives on daily life in eighteenth century London, encouraging comparisons with life today.
- 2) To assist teachers to provide pupils with the opportunity to observe, hypothesise, conduct experiments and draw their own conclusions.
- 3) To offer activities that support a range of learning needs and styles including kinaesthetic activities, independent and group work, role play, debate, note taking, and drawing.
- 4) To place the visit in context and maximise the potential for learning by providing materials for appropriate and meaningful pre-visit and follow up activities.

2. Why Visit Benjamin Franklin House?

Benjamin Franklin House offers a variety of active, enjoyable learning experiences based around the life of Benjamin Franklin and family life in the 18th century, provided in a genuinely historic Georgian period home which retains many of its original features.

Franklin was a pivotal figure in many fields and a genuine polymath – he was a printer, inventor, scientist, amateur philosopher, civic leader, diplomat, and Founding Father of the United States.

As a truly ‘self-made man’ whose parents could only afford to send him to school for two years, we feel Franklin makes a truly inspiring and fascinating figure for children to learn about and learn from. Just as important as his character are his achievements, which hold great relevance to modern life in the 21st century, making that connection between his world and that of your pupils. Franklin was actively involved in the study of electricity, and as an inventor he investigated different properties of materials and assessed their suitability for the task at hand. He had the best interests of his fellow citizens at heart, and instigated many civic improvements including a proposal for the first modern library, the first fire company there had been in Philadelphia, a university open to students of all socio-economic backgrounds, and other public services. He was present at a time when an anatomy school was being run out of the House, and this provides the basis for learning about the human body and the history of medicine. Exploring the 18th century building in the company of Franklin’s friend ‘Polly Hewson’, children are encouraged to employ and develop their historical language and to observe and compare the House and family life with their own experiences. Today we even use a number of phrases which can be traced back to Franklin, such as “*An apple a day keeps the doctor away*”, “*snug as a bug in a rug*”, and “*early to bed, early to rise, makes a man healthy, wealthy and wise*”. Taken together, Franklin and Benjamin Franklin House itself provide a wonderful starting point and context for meaningful curricular learning across a range of subjects including History, Science, English, Citizenship and Design & Technology.

We are delighted to hold both a Learning Outside the Classroom Quality Badge and a Sandford Award from the Heritage Education Trust, which recognise the excellence of our programme. Sandford Award judge Caroline Marcus stated in her 2015 report that:

“The programme clearly offered children the opportunity to participate in activities appealing to different learning styles, discuss open questions to test Franklin related inventions and ideas; learn about life in Georgian London and the advent of modern medicine and consider ways in which the past influences the present and shapes the future. The observed programme fulfilled the House’s aims to “enhance young people’s historical knowledge and satisfy scientific curiosity”.”

Please note that further reading about Franklin and his time in London can be found in Appendix I.

3. Benjamin Franklin House and the National Curriculum

*“He always began with observation and experiment, and any explanation was solidly based on fact” –
Charles Tanford, “Ben Franklin Stilled the Waves” 1989*

A visit to Benjamin Franklin House is ideal for supporting the National Curriculum’s learning objectives in *Science, History, English, Mathematics* and *Design & Technology*. Although particularly relevant to Key Stage 2, educational opportunities at the House can support all Key Stages, offering a range of curriculum enrichment opportunities for pupils with a wide variety of interests.

The full programme of activities supports several Aims of the National Curriculum in English, namely that all pupils:

- use discussion in order to learn; they should be able to elaborate and explain clearly their understanding and ideas; and
- are competent in the arts of speaking and listening, making formal presentations, demonstrating to others and participating in debate.

Specifically, a visit to Benjamin Franklin House supports the learning of **spoken language**, specifically the requirement that children are taught to:

- listen and respond appropriately to adults and their peers;
- ask relevant questions to extend their understanding and knowledge;
- articulate and justify answers, arguments and opinions;
- use spoken language to develop understanding through speculating, hypothesising, imagining and exploring ideas; and
- participate in discussions, presentations, performances, role play/improvisations and debates.

The specific learning objectives achievable on a visit are set out in Section 8 of this Pack – **An Enlightening Day**.

The key benefits to your pupils of a visit to the House include:

- A meaningful context through the work of Benjamin Franklin to explore the processes of enquiry and discovery
- Hands-on activities that are simple, structured and stimulating in order to capture children’s imaginations enabling all to be involved in proposing hypotheses and testing them
- Activities that can be easily adapted to meet the learning needs of children of different ages, levels of ability, and learning styles
- Experiences that reinforce in-school learning, especially scientific principles outlined in the National Curriculum
- Activities which demonstrate how scientific experimentation contributes to the development of technology
- A unique opportunity to explore the biography of a major Enlightenment scientist in his only remaining London home

- Relevant cross-curricular links between history and science, English, design & technology and citizenship

Thus a visit to Benjamin Franklin House provides unique opportunities for children to put learning about the scientific method to practical use through systematic investigations helping to foster a positive attitude toward science and museums. Pupils are encouraged to see that being a scientist can be stimulating, fun and achievable. They also explore the relevance and importance of science to everyday life.

4. Planning your visit

Teachers are encouraged to come to the House prior to their class visit, to review plans for the visit with the Education Manager. A risk assessment can be provided by the Education Manager if required, however teachers are welcome to conduct their own assessment in person.

A PowerPoint presentation to help prepare students for their visit can be provided on request.

As the House is quite small we do not have a lunch room, however there are a number of squares with gardens close-by to the House (see map below) where packed lunches may be eaten. Suggestions for nearby attractions with café facilities which you may also wish to visit can be found in Appendix VI, including themes or links that can be made between Benjamin Franklin House and each attraction.

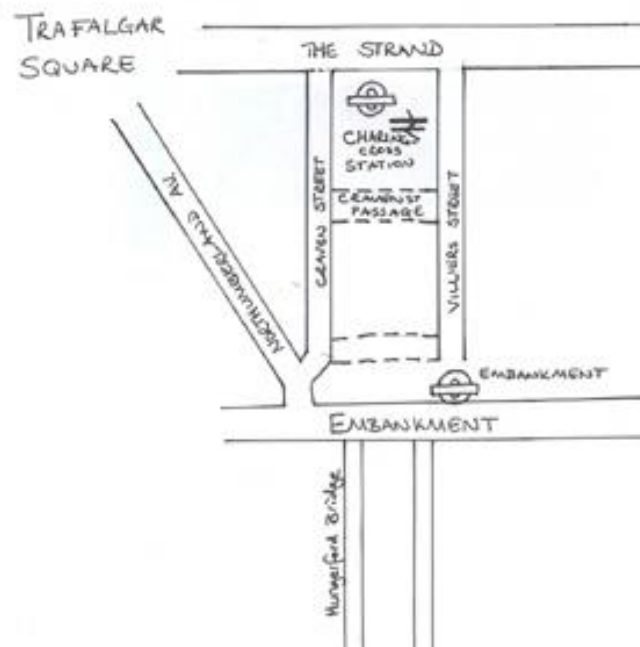

Please note that we require that a minimum of **one teacher, adult helper and/or parent is in attendance for every ten pupils.**

5. How to Book your Visit

Tuesday is our Schools Day. We offer the choice of two start times: **10.30am** and **1pm**, and the full programme lasts around 90 minutes. To book your **free** visit for your class(es), please call Benjamin Franklin House and speak to Education Manager Eleanor Hamblen at +44 (0)207 839 2013.

You can also make a provisional booking by emailing the booking form at <http://www.benjaminfranklinhouse.org/education> to the Education Manager at: education@benjaminfranklinhouse.org.

Cancellation policy

The visit to Benjamin Franklin House is free, but, if you must cancel your booking please let us know at least **14 days** before your visit to allow us to offer the session to other schools. If you must cancel your visit less than 14 days in advance, we will ask you to make a donation to Benjamin Franklin House (registered charity no. 276066), to help lost costs such as the fee for our actress and other staff time, as we cannot fill open sessions at such short notice.

Contact details:

Eleanor Hamblen
Education Manager
Benjamin Franklin House
36 Craven Street
London WC2N 5NF
Telephone: +44 (0)207 839 2013
Email: education@benjaminfranklinhouse.org

6. Setting Objectives for the Visit

In order for pupils to benefit as much as possible from the visit, it is naturally important to set clear learning objectives.

Our activities demonstrate how Franklin's work was driven by a real spirit of enquiry, awe and curiosity about the world in which he lived. This led him to ask questions, seek answers and develop solutions. We demonstrate how he applied his knowledge and understanding to practical purposes, an approach which is central to the science curriculum in particular. As discussed in Section 3 above, the offerings at Benjamin Franklin House were originally developed and continue to be adapted to support the **National Curriculum**. We ensure that all activities are appropriate for the age and experience of the children, and our staff and volunteers are experienced in tailoring presentations to the learning styles and abilities of the children in each class, to ensure they all benefit from the experience.

We emphasise learning through experimentation. Benjamin Franklin House promotes **knowledge and understanding** (including science, history, design and technology, life in Georgian London), **transferable skills** (such as teamwork, problem solving, learning how to look at objects, experimenting, making deductions, and communication), and **personal development** (increasing motivation and confidence, changing children's views about museums, science and history, encouraging them to take their learning further by visiting other museums and involving their families).

Each activity your class will participate in has clearly identified learning outcomes, as described in the National Curriculum, and these are set out under the headings of Delivering the Curriculum in the An Enlightening Day section of this Pack (pages 12-20).

7. Preparing your Pupils

To make any visit meaningful, it is naturally important pupils are prepared for the visit. A supporting resource, a PowerPoint presentation entitled **Benjamin Franklin, 18th Century Superhero**, which takes the form of a comic book, will be provided separately. We encourage you to use Part 1 of the presentation, entitled 'From Humble Beginnings', to introduce your class to Benjamin Franklin, and explore who he was and what he accomplished. Part 2 of the presentation, 'A Man Of Many Personas', is intended to support the supplementary, follow-up activities which are outlined in the Plenary section of this Pack at p21, and are detailed in the lesson plans available separately for free.

Benjamin Franklin, 18th Century Superhero

Teachers are encouraged to use this presentation as they see fit, either as a prompt for some explorative questioning or as a reading resource. It has been developed to introduce Benjamin Franklin and to create a sense of anticipation for your class visit. Part 1 of the presentation, entitled 'From Humble Beginnings', provides some background on Franklin's family life and limited schooling. It concludes with Franklin arriving in London in 1757, thus setting the scene for the visit where your pupils will learn all about Franklin's time at 36 Craven Street.

We accept, however, that you may wish to prefer to take a different approach to preparing your class. Ultimately, we would recommend that you explain the purpose of the visit and any success criteria, as you would for any lesson in school. You might wish to notify them in advance of any relevant follow up work they will be doing once they return to school.

Here are some other preparatory activities you might wish to consider as alternatives to the presentation:

• To provide some context for the visit:

Ask your pupils a few questions to generate interest and discussion. You might wish to ask:

- 1) Why was Benjamin Franklin so important that we are still talking about him today?
- 2) How do you think scientific discoveries are made?
- 3) How do you think surgery was performed in the 18th century?
- 4) What do we use electricity for today?
- 5) What was life in London like 250 years ago?

In addition to researching the answers in books or online, you might consider doing teacher-in-role. You can ask the same questions after the visit to see what has been learned and how perceptions have changed.

You could also create a fact-finder mission for your pupils to work through during their visit, based on the resources and background information in this Pack. For instance, you could challenge your class to find out

the name of as many of Benjamin Franklin's inventions as they can. Franklin is also an excellent inspiration for an enterprise project. For instance, a campaign to promote your local library (Franklin founded the first subscription library) or a topic on emergency services (Franklin founded the first Fire Company for the city of Philadelphia).

- **Investigating the House online**

At www.benjaminfranklinhouse.org, pupils can gain information about the House in advance. They can also read more about our other programmes and events.

8. An Enlightening Day

A visit to Benjamin Franklin House normally takes around 90 minutes. The maximum number of pupils per session is 30. The class will be split into two or three equal sized groups, depending on the total number of pupils. These groups in turn see the Historical Experience, the Student Science Centre, and the Discovery Room & Medical History Room carousel-style. Each of these three activities takes around 25 minutes.

I – Historical Experience

In the company of Franklin's 'adopted daughter' Polly Hewson, pupils explore the 18th century building where Franklin lived during his time in London. This special journey removes the traditional distance between museum and child, bringing a sense of the innovation that characterised Franklin's life in London.

Children gain a sense of the times in which he lived: insight into 18th century food, health, botany, and daily living in the basement kitchen, social and personal relationships on the ground floor, scientific work and political drama on the first. The visit gives children insight into the final moments when Britain and America were still one and what led to their separation.

- **Delivering the Curriculum**

The Historical Experience allows children to access history through drama. Specifically, it supports the study of **local history** and encourages children to **devise historically valid questions** about similarity and difference specifically, as required by the National Curriculum for History at Key Stage 2.

The Historical Experience meets an aim of the English curriculum relating to 'Spoken Language', that is to provide children with the opportunity to **respond thoughtfully to drama and theatre performances**.

The content of the Historical Experience also reinforces learning objectives achieved through our other activities, which are described below, in science in particular.

II – Student Science Centre

The SSC consists of three different rooms:

1. Demonstration Room

Benjamin Franklin was a practical scientist, and in the Demonstration Room students gain insight into the great man's mind. They will reproduce one of his London-based scientific enquiries and see how this led to amazing inventions. Invention can be hard to explain. Where does inspiration come from, and how can you imagine an entirely new thing? The Student Science Centre is unique in offering students an insight into the process of invention.

The Education Manager creates an exciting demonstration for students, aided by video and hands-on experimentation. Before their visit, teachers choose one of three alternatives described below: **The True Nature of Lightning; Inventing the Glass Armonica; or Investigating Canals.**

A) The True Nature of Lightning

Franklin's most spectacular achievement was explaining the true nature of lightening and inventing a way of protecting people from its awesome power. He did this first in Philadelphia but repeated his electrical experiment in London. This demonstration consists of spectacular video footage and experiments that provide insight into the way scientists enquire about the world around them.

- **Delivering the Curriculum**

The lightning demonstration provides a great opportunity for cross-curricular learning, furthering knowledge of electricity and enabling children to develop an understanding of a natural phenomenon through observation of this visually stimulating experiment.

Specifically, this demonstration supports the teaching of the following curricular learning objectives for **Science** at Key Stage 2:

Lower Key Stage 2, Working scientifically. Pupils should be taught to use the following practical scientific methods, processes and skills:

- asking relevant questions and using different types of scientific enquiries to answer them
- identifying differences, similarities or changes related to simple scientific ideas and processes
- using straightforward scientific evidence to answer questions or to support their findings.

Year 4, Electricity. Pupils should be taught to:

- recognise some common conductors and insulators, and associate metals with being good conductors.

Upper Key Stage 2, Working scientifically. Pupils should be taught to use the following practical scientific methods, processes and skills:

- identifying scientific evidence that has been used to support or refute ideas or arguments

Year 5, Properties and changes of materials. Pupils should be taught to:

- compare and group together everyday materials on the basis of their properties, including their hardness, solubility, transparency, **conductivity** (electrical and thermal), and response to magnets
- give reasons, based on evidence from comparative and fair tests, for the particular uses of everyday materials, including metals, wood and plastic

Year 6, Electricity. Pupils should be taught to:

- take the necessary precautions for working safely with electricity

This well-structured demonstration guides the children through the processes of scientific enquiry and invention, starting with Franklin's observations that lightning was electrical in nature and ending with the invention of the lightning rod. Electricity is therefore 'brought to life' in a way children have never seen before.

- **How the Demonstration Works**

A large table is set up with a device known as a Tesla coil mounted at one end. Safety barriers are put in place to stop students getting too close to the coil. The demonstration involves placing a model Franklin with copper kite and metal key next to the coil, replicating Franklin's original experiment. The electrical charge built up by the Tesla coil causes sparks to jump to the dangling key.



To demonstrate the 18th century challenge of protecting buildings from lightning, which Franklin addressed, a model church (with a metal wire running from top to bottom) is used. When placed close to the Tesla coil, sparks strike the church and 'zap' the building. Children then discover Franklin's ingenious solution of the lightning rod, and in so doing, experience a clear, visual demonstration of the difference between electrical **conductors** and **insulators**.

B) Inventing the Armonica

Benjamin Franklin was one of the first Americans to invent a musical instrument. This demonstration leads students through his design process, giving them a great example of how invention can involve every day items, based on a simple hypothesis. The demonstration involves scientific enquiry and an investigation of form and function, encompassing aspects of both science and technology.

- **Delivering the Curriculum**

The Armonica demonstration brings together *Science* and *Design & Technology*, providing insight into the way products are developed, emphasising the contribution of scientific understanding. Children are shown the importance of science in our everyday lives and experience the excitement of creating a 'new' instrument.

Specifically, it teaches the following curricular learning objectives in **Science**:

Lower Key Stage 2, Working scientifically. Pupils should be taught to use the following practical scientific methods, processes and skills:

- asking relevant questions and using different types of scientific enquiries to answer them
- identifying differences, similarities or changes related to simple scientific ideas and processes
- using straightforward scientific evidence to answer questions or to support their findings.

Year 4, Sound. Pupils should be taught to:

- identify how sounds are made, associating some of them with something vibrating
- recognise that vibrations from sounds travel through a medium to the ear

Upper Key Stage 2, Working scientifically. Pupils should be taught to use the following practical scientific methods, processes and skills:

- identifying scientific evidence that has been used to support or refute ideas or arguments.

Year 5, Properties and changes of materials. Pupils should be taught to:

- compare and group together everyday materials on the basis of their properties, including their hardness, solubility, transparency, conductivity (electrical and thermal), and response to magnets
- give reasons, based on evidence from comparative and fair tests, for the particular uses of everyday materials, including metals, wood and plastic

The experiment is fun and engages all those participating, encouraging children to ask questions. All will have the chance to play the instrument and make music for themselves.

- **How the Demonstration Works**

A selection of wine glasses of different shapes and sizes, filled with different volumes of water, are displayed. The Education Manager shows the students how to make a sound by gently rubbing a wet finger round the rim of a glass, while they discuss the principles of sound. Several stages follow in which the children explore different materials and how to make the instrument easier to play.

In the final part of the demonstration the Education Manager reveals a real Glass Armonica and the children experiment at playing a tune. They follow in the footsteps of Franklin in creating an improved instrument.

At different points in the demonstration the children are shown relevant video clips, including House friend Alastair Malloy of the BBC Orchestra playing a piece Mozart composed for Franklin's unique instrument his own Armonica.



C) Investigating Canals

Franklin's investigation into canals is a fantastic example of scientific enquiry. He observed something he couldn't explain, why boats in some canals seemed to travel faster than others, and set about devising a model that would allow him to test the problem. This workshop provides a clear visual demonstration of the 'scientific method' in action, in particular the concepts of 'variables' and what makes a 'fair test'.

- **Delivering the Curriculum**

The canal demonstration allows children to be involved in an investigation demonstrating how Franklin used observations to make further predictions. It provides a real life context for learning about forces and working scientifically.

Specifically, it teaches the following curricular learning objectives in **Science**:

Lower KS2, Working scientifically. Pupils should be taught to use the following scientific methods, processes and skills:

- asking relevant questions and using different types of scientific enquiries to answer them
- setting up simple practical enquiries, comparative and fair tests
- making systematic and careful observations and, where appropriate, taking accurate measurements using standard units, using a range of equipment, including thermometers and data loggers
- gathering, recording, classifying and presenting data in a variety of ways to help in answering questions
- recording findings using simple scientific language, drawings, labelled diagrams, keys, bar charts, and tables
- reporting on findings from enquiries, including oral and written explanations, displays or presentations of results and conclusions
- using results to draw simple conclusions, make predictions for new values, suggest improvements and raise further questions
- identifying differences, similarities or changes related to simple scientific ideas and processes
- using straightforward scientific evidence to answer questions or to support their findings

Year 3, Forces and Magnets. Pupils should be taught to:

- compare how things move on different surfaces

Upper KS2, Working scientifically. Pupils should be taught to use the following scientific methods, processes and skills:

- planning different types of scientific enquiries to answer questions, including recognising and controlling variables where necessary
- taking measurements, using a range of scientific equipment, with increasing accuracy and precision, taking repeat readings when appropriate
- recording data and results of increasing complexity using scientific diagrams and labels, classification keys, tables, scatter graphs, bar and line graphs
- using test results to make predictions to set up further comparative and fair tests
- reporting and presenting findings from enquiries, including conclusions, causal relationships and explanations of and a degree of trust in results, in oral and written forms such as displays and other presentations
- identifying scientific evidence that has been used to support or refute ideas or arguments

Year 5, Forces. Pupils should be taught to:

- identify the effects of air resistance, **water resistance** and friction, that act between moving surfaces

This demonstration also allows cross-curricular links to be made to **Mathematics** in lower KS2 as follows:

Statistics. Pupils should be taught to:

- interpret and present data using bar charts, pictograms and tables (Year 3)
- interpret and present discrete and continuous data using appropriate graphical methods, including bar charts and time graphs (Year 4)
- solve comparison, sum and difference problems using information presented in bar charts, pictograms, tables and other graphs (Year 4)

- **How the Demonstration Works**

Two canals run along the length of a table. A vertical pulley mechanism slots into place at one end. Small weights (teaspoons) are attached to strings that pass over the pulleys and run along the canals filled with water – one to a depth of 2cm, the other to 4cm. Small boats made from shampoo bottles float on the canal. Strings are attached to the boats and the weights are released to pull the boats through the water. This simple system allows investigation of factors that influence canal boat speed.

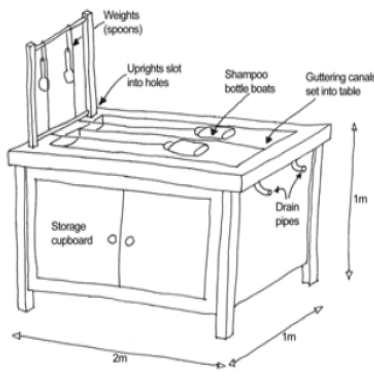

Students discover variables that can be modified affecting the results: Depth of water, weight of pulley, weight of canal boat, shape of canal boat, loading of canal boat. They ultimately discover whether boats travel faster in deeper or shallower canals.

2. Discovery Room

The Discovery Room houses four touch-screen computers, allowing students several minutes to complete one of several engaging interactive games. Students are invited to choose a replica artefact from a box and then must match their item to the relevant game. Each game aims to encourage the player to consider an object's form in order to predict its function.

The six objects to choose from are split into two groups: household objects that could have been found at Craven Street; and bones relating to William Hewson's Craven Street Anatomy School. They include: a jaw from a cow; a washboard; an ink well; and a surgeon's bone saw.

- **Delivering the Curriculum**

In the Discovery Room children explore form and function and invention.

The activities incorporate **Computing** as pupils use the touch-screen computers to find out information. The computer games are fun and straightforward and take them through the process of invention in a few short steps. The visual, hands-on nature of this activity engages children and can be particularly beneficial to more visual learners.

3. Medical History Room

Inspired by the anatomy school of Mr William Hewson, this room contains a number of separate activities focused on human anatomy. The activities in this room are less structured, allowing the students freedom to explore the room's contents. All exhibits are suitable for both individual and group activity.

- **Delivering the Curriculum**

Pupils learn about how the body works in a fun and informative, yet less formally structured session. The Medical History Room also encourages children to use the reference material available to extend their learning.

The Medical History Room explores the wonders of how the human body works and fits together. It relates to the National Curriculum for KS2 **Science**, specifically the following learning outcomes:

Animals, including humans. Pupils should be taught to:

- identify that humans and some other animals have skeletons and muscles for support, protection and movement (Year 3)
- describe the simple functions of the basic parts of the digestive system in humans (Year 4)
- identify and name the main parts of the human circulatory system, and describe the functions of the heart, blood vessels and blood (Year 6)

Pupils discover the heart's purpose in helping to circulate blood through vessels around the body and how humans have skeletons and muscles to support and protect our bodies and make them move.

- **How the Medical History Room Works**

A) Interactive Circulation Game

Students learn how the heart sends blood to the lungs to pick up oxygen, and then around the rest of the body to deliver oxygen to muscles and organs.

The circulation game consists of a large body diagram, with body areas illuminated with LED lights. The aim is for the students to connect the areas together correctly. If they do, the heart pumps, the brain lights up and even butterflies turn in the stomach.



B) Bones and Organs

Students put on magnet covered tabards, to which they can attach either organs or bones made of soft materials with descriptions of the organs and bones and some diagrams for assembly. Students can be organised into teams to compete in arranging their bones and organs in the fastest time.



C) Reference Material and William Hewson Display Panel

A series of panels describe the work of the pioneering anatomist William Hewson, who married Polly, daughter of Franklin's landlady. They discover more about his training and life including pertinent details about medical research in the eighteenth century such as the source of the bodies used in dissections!

9. Back at School - Assessing Learning

Each class which visits Benjamin Franklin House is entitled to a complimentary follow-up outreach workshop led by the Education Manager in the classroom. The aim of this workshop is to consolidate and supplement pupils' learning during their visit to BFH, as described below.

Ben's Travelling Suitcase

The Education Manager can visit your school to run a free outreach session with *Benjamin Franklin's Travelling Suitcase*. The valise, seen below, is full of objects related to Franklin's innovations, making a tangible real-life connection to Franklin's life in London. It promotes the 'scientific method' of drawing conclusions based on an examination of the available evidence. The objects in Ben's Travelling Suitcase provide inspiration for group and class discussion and encourage young people to visit museums with their families to further their learning.



There are three different workshops to choose from: **Become an Inventor**, **Look at Me! A lesson in 18th Century Portraiture** or **Franklin's Fables**. Visit <https://benjaminfranklinhouse.org/education/outreach/> for more information.

We strongly recommend you book your outreach visit at the same time as your visit to BFH. This outreach visit is best made within a few days of the original visit. To find out more or to book an outreach session please contact Eleanor Hamblen at: education@benjaminfranklinhouse.org.

Plenary

Once back in school, either or both of the recommended follow-up activities '**Create your own Comic**' and '**Super-Bio**' could be used to assess children's learning from their visit and extend it. Lesson plans for these activities, which refer to Part 2 of the PowerPoint presentation **Benjamin Franklin, 18th Century Superhero, 'A Man Of Many Personas'**, can be provided separately.

Alternatively, your pupils could be encouraged to discuss the following questions in pairs or groups before presenting to their peers, or simply as a whole class:

- What was their favourite room in the House and why?
- What did they learn about science that they did not know before?
- What was positive about their visit to Benjamin Franklin House?
- What could have been better?
- Has the visit made them think about history, scientists, or old buildings in a different way?

Pupils' answers to the first three questions could form the basis of an art project, a dramatic performance/skit, or a piece of informative writing.

Teachers may wish to ask pupils the same 5 key questions after the visit they were asked before to see what has been learned and how perceptions have changed:

- 1) Why was Benjamin Franklin so important that we are still talking about him today?
- 2) How do you think scientific discoveries are made?
- 3) How do you think surgery was performed in the 18th century?
- 4) What do we use electricity for today?
- 5) What was life in London like 250 years ago?

10. Other Curriculum Enrichment Opportunities with Benjamin Franklin House

Science on Stage

British Library Eccles Centre, Monday 20th May 2019

At Science on Stage, special guest presenters capture children's attention with experiments that pop, crackle and illuminate, showing how Franklin's 18th century explorations led to some of today's most important technologies. Attendance is by invitation only, and first priority for places is given to schools who have booked a visit to Benjamin Franklin House during the current school year.

Science Fair

Benjamin Franklin House, Summer Term 2019

As part of their summer term science topic, pupils from schools across London are supported by us to devise and conduct an experiment (or series of them) of their choosing. Pupils plan the experiment, research, propose a hypothesis, conduct the experiment, record their results, and reach conclusions. The experiment can be documented in a variety of ways e.g. topic books, posters, photos, videos etc., and these are presented, along with the experiment itself, at Science Fair. Guidance on what kinds of experiments might support your summer term topic can be provided if desired.

Science Fair is judged by a representative of the [Royal Institution](#), an organisation at the forefront of public engagement with science whose charitable purpose has always been to encourage people to think more deeply about the wonders and applications of science. Prizes will be awarded to the team producing the best project.

Sister Schools

In-school, any time

Sister Schools pairs schools in London with schools in the US for a collaborative project or series of lessons exploring the life of Ben Franklin, and supports the teaching of **science, design & technology, English, and citizenship**. Schools can choose the level of time commitment that best suits them, as follows:

- I. A set of four cross-curricular lessons, each exploring a different aspect of Franklin's life. A Teacher's Pack containing lesson plans and resources is provided separately, as is the use of a secure bespoke website where pupils' work can be shared with their counterparts in the US. Time required: 8 hours.
- II. A one-off citizenship project exploring a local, national or international problem and devising a way to solve it. At your discretion, this can be extended into an enterprise project, for example a campaign to save a local public service, raise funds for local community centre etc. Time required: 4 hours.

More information about each of these events and projects can be found here: <http://www.benjaminfranklinhouse.org/site/sections/education/default.htm>. To discuss your participation, please do not hesitate to get in touch using the contact information provided on p2 of this Pack.

Appendix 1 – What is special about Benjamin Franklin and his London Home? – Background information for teachers

Benjamin Franklin House at 36 Craven Street in the heart of London is a heritage 'gem'. The House, built circa 1730, is architecturally very significant. It holds a Grade I listing and retains a majority of original features, (central staircase, lathing, 18th Century panelling, stoves, windows, fittings, beams, brick, etc) 'unimproved' over time. As the world's only remaining Franklin home, it is also historically significant:

- Franklin lived here for sixteen years on the eve of the American Revolution between 1757 and 1775 (he returned to the US between 1762 and 1764).
- Is the first de facto US Embassy - a special place in Anglo-American history
- Plays a fascinating role in the history of medicine - Franklin's landlady's son-in-law ran an anatomy school from Craven Street
- The House has additionally gained official recognition:
 - First site outside the US to achieve Save America's Treasures designation
 - Recognised by Tercentenary Committee (celebrating 300th anniversary of Franklin's birth in 2006) established by the White House
 - Institute of Electrical Electronics Engineers (IEEE) 'Milestone' location

During his tenure at the House, Franklin interacted with eminent thinkers, scientists and political leaders of his day including [Edmund Burke](#), [David Hume](#), [Joseph Priestley](#) and [Adam Smith](#). His role, however, was not restricted to that of ambassador or politician.

Franklin conducted many important experiments, such as measuring the effects of the Gulf Stream, wrote his autobiography, and worked as an inventor. One of his inventions, the Glass Armonica, is a musical instrument for which Mozart and Beethoven composed. The House also served as the anatomy school of the pioneering [William Hewson](#), who married Polly, daughter of Franklin's landlady Margaret Stevenson.

In 1998, excavation of the basement uncovered bones, apparently discarded following student dissections, which provide fascinating information about the early history of surgery.

Both a dynamic museum and educational facility, Benjamin Franklin House provides an excellent opportunity to introduce pupils to the important concepts of science, history and design and technology. We recognise that due to a lack of information or limited resources, some children do not get the same chance as others to visit museums. Therefore all activities are free of charge. Through a wide programme of educational and fun activities, we ensure the participation of children from different backgrounds.

Who was Benjamin Franklin?

Benjamin Franklin (January 17, 1706 – April 17, 1790) was an American printer, journalist, publisher, author, philanthropist, abolitionist, public servant, scientist, librarian, diplomat, inventor, and more. A

leader of the American Revolution, well known also for his many quotations, he is considered the 'father' of electricity. Franklin's inventions include the Franklin stove, the flexible urinary catheter, the lightning rod, swim fins, improvements to the glass Armonica. He is sometimes credited with inventing bifocal glasses.

Benjamin Franklin was born in Boston, Massachusetts. His schooling ended aged ten and at the age of twelve he became an apprentice to his brother James, a printer who published the *New England Courant*. While a printing apprentice, he wrote precociously under the pseudonym of 'Mrs. Silence Dogood' in the guise of a middle-aged widow.

Aged 17 he ran away to Philadelphia seeking independence in a new city. However, he soon realised that if he wanted to set up as a publisher on his own, he needed to come to London to learn more about the trade. After working as a compositor in a printer's shop, he returned to Philadelphia after a couple of years and in 1730 set up a printing house of his own from which he published *The Pennsylvania Gazette*, one of the premier newspapers of Colonial America. The *Gazette* gave Franklin a platform from which to pursue a variety of local reforms.

He combined his intelligence with a great deal of savvy about cultivating a positive image as an industrious and intellectual young man, earning him a great deal of respect.

In 1732 Franklin began to publish the famous *Poor Richard's Almanack*, which strengthened his reputation. Adages from this almanac such as "A penny saved is two pence clear" (often misquoted as "A penny saved is a penny earned") and "An apple a day keeps the doctor away" are now commonly used by people all over the world.

As a printer and a publisher of a newspaper, Franklin frequented the farmers' markets in Philadelphia to gather news. One day he inferred that reports of a storm elsewhere in Pennsylvania must be the same storm that had visited Philadelphia a few days before. This gave him the notion that *some storms travel*, eventually leading to the synoptic charts of dynamic meteorology.

In 1731 Franklin and other like-minded friends who called themselves *The Junto*, began the first public library in Philadelphia, and in 1736 Franklin created the Union Fire Company, the first volunteer fire fighting company in America.

Franklin then began to concern himself increasingly with public affairs. He set out a scheme for The Academy and College of Philadelphia, which was later merged with the University of the State of Pennsylvania, to become the University of Pennsylvania which is today a member of the so-called Ivy League of top US universities. He also founded an American Philosophical Society to help those interested in science discuss their discoveries, and began research into electricity, which, along with other scientific inquiries would occupy him the rest of his life.

In 1748 Franklin retired from printing, creating a partnership with his foreman, David Hill, which provided Franklin with half of the shop's profits for 18 years. This lucrative business arrangement provided leisure time for study, and in a few years he had made discoveries that gave him a global reputation.

In 1750, after a series of discoveries in energy, Franklin published a proposal for an experiment to prove lightning was electricity and not an act of God, as it was then believed. Franklin's kite and key experiment and subsequent invention of the lightning rod led to Franklin's election as a Fellow of the Royal Society.

In 1751 Franklin established the Pennsylvania Hospital – the first in America.

In politics, he proved very able both as an administrator and a passionate proponent of political freedom. One of his notable contributions in domestic affairs was a modern postal system, while his fame as a statesman rests on his diplomatic service as representative of the American colonies in Great Britain and France. He was awarded an honorary doctorate for his scientific accomplishments both from St. Andrews and Oxford University.

In 1757 Franklin was sent to England to ask the Penn family, proprietary owners of Pennsylvania to provide greater financial support. He took lodgings with the widow Margaret Stevenson and her daughter Polly in their house at 36 Craven Street. Franklin was said to be less of a lodger than the head of household living in serene comfort and affection. Leaving his wife Deborah, who was afraid of crossing the ocean, and daughter Sally behind in Philadelphia, Franklin had found a surrogate family in the Stevenson Household.

He strove to inform the British people and government about colonial conditions.

He returned to Pennsylvania briefly in 1762, but in 1764 was again dispatched to England to advocate against taxation without representation.

Although times were turbulent, Franklin continued to engage with friends and scientific colleagues. While at Craven Street he explored a wide range of issues from lead poisoning and the common cold to magnetism.

In 1765 Parliament imposed a stamp duty on, among other things, colonial legal documents and newspapers. Franklin argued against the tax using both the press and social occasions to influence government leaders. A year later he was called as a witness before the House of Commons, where he gave a masterly performance answering over 170 questions. The Act was repealed a month later, but in 1767 relations between Britain and the colonies worsened as duties were levied on glass, paper and tea.

Despite the tensions, Franklin worked tirelessly toward reconciliation, attracting criticism from both sides. He could not, however, prevent the escalation of misunderstanding on both sides, and thus his final stay in London came to a close. By the time he stepped ashore in Philadelphia in May 1775, the American Revolution had already begun.

In 1778 Franklin was sent to France to gain French support for American Independence. He remained in France until 1785. A favourite of French society, Franklin was so popular that it became fashionable for wealthy French families to decorate their parlours with paintings of him. He was so influential in securing support for America and negotiating the Treaty of Paris (1783) that ended the revolutionary war, that when he finally returned home he was celebrated as the champion of American Independence.

After his return from France at the age of seventy nine, Franklin took an active stand against slavery and helped shape the American Constitution. He is the only Founding Father who signed all four documents essential to the founding of the United States: The Declaration of Independence (1776), The Treaty of Alliance with France (1778), the Treaty of Paris establishing peace with Britain (1783) and the United States Constitution (1787). Franklin died on April 17, 1790 at the age of eighty four. Twenty thousand people attended the funeral of the man whose electric personality still lights the world.

Educational resource - A biographical timeline of Benjamin Franklin's scientific endeavours for use with your class can be found in [Appendix 2](#).

Appendix 2 – Timeline: Franklin the Scientist

Timeline of key discoveries, inventions and events:

- 1717 - Invents wooden swim fins and sandals, which resembled flippers
- 1742 - Invents the Franklin stove, intended to be more fuel-efficient than the stoves of the day
- 1743-47 – First writings on experimentation into electricity, specifically static electricity
- 1752 – Conducts kite experiment in Philadelphia
- 1760 - Investigates the effect of colour on heat absorption, reaches conclusion that darker fabrics absorb more heat than lighter fabrics *
- 1761 – Invents a musical instrument, the Glass Armonica *
- 1762 – Investigates the calming effect of oil on water at Clapham Common pond *
- 1768 – Observes changing speeds of barges down canals, investigates and proves that a deeper canal results in faster travel *
- 1769 – Lightning rod of Franklin’s design fitted to St Paul’s Cathedral *
- 1768-1770 – Charts the Gulf Stream, with assistance from his cousin Timothy Folger and other ship captains *
- 1772 – Again experiments with oil on water, this time at Derwent Water, Lake District, with John Pringle *
- 1775 - Invents the odometer, a device to measure the distance a carriage has travelled
- 1784 – Popularises “Double Spectacles” (bifocal glasses) while living in Passy, France
- 1786 - Invents the Long Arm, a device used to reach books on high shelves

* Occurred during Franklin’s tenure at 36 Craven Street.

Appendix 3 – Background reading

Recommended Books for Children and Young People

There are a great many children's books of varying quality written about Benjamin Franklin, though many can be hard to source outside the US. We recommend the following books, which are available in the UK:

Ages 5-7

[Now and Ben](#), by Gene Barretta

[How Ben Franklin Stole the Lightning](#), by Rosalyn Schanzer

[A Picture Book of Benjamin Franklin](#), by David A. Adler

Ages 8-11

[Benjamin Franklin: A Man of Many Talents](#), Time Magazine for Kids Biographies

[Amazing Ben Franklin Inventions You Can Build Yourself](#), by Carmella Van Vleet

Ages 12+

[Benjamin Franklin, American Genius](#), by Brandon Marie Miller

Recommended Websites

Websites you might find helpful:

Benjamin Franklin Tercentenary: www.benjaminfranklin300.org

This website is the online companion to the travelling exhibition commissioned to commemorate, what would have been Franklin's 300th birthday in 2006. The site contains lesson plans, resources including trivia questions, and photos of a wide variety of Franklin-related artefacts. The lesson plans are tailored for US schools, but should be easily adaptable.

Public Broadcasting Service (PBS): <http://www.pbs.org/benfranklin/>

This micro site accompanies a PBS documentary on Franklin and consists of biographical information, a teacher's guide, and useful resources such as an interactive timeline of Franklin's life, a Franklin A to Z, and an excellent game relating to his lightning experiment.

Links for further information on Franklin's life and work:

American Philosophical Society: www.amphilsoc.org

Official website of the Society dedicated to 18th century knowledge formed by Benjamin Franklin in 1743.

Franklin Institute Online: www.snlf.edu

Official website of the Franklin Institute, a science museum in Philadelphia, Pennsylvania, which was established in 1824 to inspire a passion for learning about science and technology; contains various teaching resources to support visits to the Institute, though some may be adaptable.

Institute of Electrical & Electronics Engineers Historical Centre:

http://www.ieee.org/about/history_center/index.html

Website of the IEEE's History Centre, a non-profit organization which seeks to preserve, research, and promote the legacy of electrical engineering and computing. Franklin has been celebrated by the IEEE for his pioneering research into electricity and Benjamin Franklin House is an IEEE Milestone Location.

University of Pennsylvania: www.upenn.edu/

Official website of the Ivy League university which Franklin founded in 1740.

Appendix 4 – Checklist for your Visit

Completing this checklist might help you prepare for your visit. Check that you have:

- Made the purpose and details of the visit clear to everyone involved (colleagues, helpers, Benjamin Franklin House staff);
- Confirmed your booking in writing/by email, including the follow-up outreach visit if desired;
- Obtained permission slips from all parents;

- Informed parents about the purpose of the visit, what the lunch arrangements are, and what time they will be back at school;
- Organised appropriate provision for any pupil(s) with special needs;

- Arranged transportation;

- Organised adequate staff supervision;

- Checked insurance cover; and

- Left mobile number and itinerary with the school secretary.

We hope you enjoy your day at our House and that you choose to return in the future!

Appendix 5 – How to get to Benjamin Franklin House

Nearest Tube/British Rail: Charing Cross (Northern and Bakerloo Lines), Embankment (District and Circle Lines)

From Charing Cross: Turn left out of the main station entrance, to Craven Street, the first turning. We are on the left side of the street.

From Embankment: Exit the station walking up Villiers Street. Turn left through the Arches shopping parade, and up the stairs onto Craven Street. The House will be on your right toward the top of the street at No. 36.

Buses:

There are a number of buses that stop near Craven Street, including 6, 9, 11, 13, 15, 23, 77a, 91, 139, 176.

Car/Coach

Because parking nearby is difficult; we urge visitors to use public transport. Coaches may drop off, but not park.

Congestion Charge Zone: Please note that Benjamin Franklin House is situated within the congestion charge zone (£10.00).

A short PowerPoint presentation for use with your class, which contains guidance for your journey, can be provided on request.

For more advice on planning your journey to Benjamin Franklin House, visit our website or see the Transport for London website: <http://www.tfl.gov.uk/journeyplanner>



Appendix 6 – Other relevant attractions to visit

There are a number of museums, historic houses/sites and galleries that you may wish to visit while you and your class are in central London, either before or after your visit to Benjamin Franklin House. We are pleased to recommend the education programmes of the following local attractions:

Dr Johnson's House, 17 Gough Square, London EC4A 3DE

Dr Johnson's House is a charming 300-year-old townhouse, nestled amongst a maze of courts and alleys in the historic City of London. Samuel Johnson, the writer and wit, lived and worked here in the middle of the eighteenth century, compiling his great Dictionary of the English Language. Dr Johnson's House runs a lively education programme that includes workshops for schools, outreach sessions and a range of tours and talks which are free or low cost. For more information visit: <http://www.drjohnsonshouse.org/education.html>.

Foundling Museum, 40 Brunswick Square, London WC1N 1AZ

The Foundling Museum tells the story of the Foundling Hospital, London's first home for abandoned children. Every term the Museum runs a series of artist-led schools workshops and provides resources for self-directed visits. Both the artist-led workshops and the resources encourage teachers and students to critically engage with eighteenth century and contemporary art and objects. For more information visit: <http://www.foundlingmuseum.org.uk/learning/>.

Ragged School Museum, 46-50 Copperfield Road, London E3 4RR

Housed in what was once London's biggest Ragged School, this popular, family-friendly museum welcomes people of all ages to taste a slice of Victorian life. The Museum offers, through roleplay, hands-on exhibits and talks, an authentic and memorable experience of the poor of the East End a century ago. For more information visit: <http://www.raggedschoolmuseum.org.uk/overview/>.

Education Manager's note

A visit to Dr Johnson's House or the Foundling Museum would make a nice complement to a visit to Benjamin Franklin House if the Georgian period is of particular interest. Alternatively, the 'Victorian classroom' experience at the Ragged School Museum is truly memorable and makes wonderful use of a costumed interpreter through whom pupils can access the history of the period and the School in particular, as pupils do at BFH.

If you do choose to book a complementary visit to one of these attractions, please tell them we sent you!

36 Craven Street London WC2N 5NF United Kingdom

Phone: +44 (0)207 839 2006

Website: www.benjaminfranklinhouse.org

The Friends of Benjamin Franklin House (UK), registered charity no. 276066

Registered in England, company no. 01362091

